



Pro Maxx

Speaker Systems

DESIGNED, ENGINEERED AND MANUFACTURED IN ITALY

ENGLISH

 МУЗЦЕНТР
МУЗЫКАЛЬНОЕ ОБОРУДОВАНИЕ
<https://muzcentre.ru>



INDEX

ATTENTION-PRECAUTIONS	1
INTRODUCTION	2
AMPLIFIER MODULE	2
GENERAL FEATURES	3-4-5-6
ProMaxX 14A / 14	
ProMaxX 12A / 12	
ProMaxX 10A / 10	
ProMaxX 15SA	
CONTROLS AND FUNCTIONS	7-8-9
ProMaxX 14A / 14	
ProMaxX 12A / 12	
ProMaxX 10A / 10	
ProMaxX 15SA	
PRESET	10
CONNECTORS	11
DIMENSIONS	12-13-14
SAFETY INSTRUCTIONS	15
ACCESSORIES	16
INSTALLATION MODE	17-18
CONNECTION EXAMPLES	19-20
TECHNICAL SPECIFICATIONS	21-22



**RISK OF ELECTRIC SHOCK
DO NOT OPEN**

**TO REDUCE THE RISK OF ELECTRIC SHOCK
DO NOT REMOVE COVER (OR BACK)
NO USER SERVICEABLE PARTS INSIDE
REFER SERVICING TO QUALIFIED SERVICE PERSONNEL**

**TO REDUCE THE RISK OF FIRE OR ELECTRIC SHOCK
DO NOT EXPOSE THIS EQUIPMENT TO RAIN OR MOISTURE**



WHERE MARKED, THIS SYMBOL INDICATES A DANGEROUS NON-ISOLATED VOLTAGE INSIDE THE LOUDSPEAKER. SUCH VOLTAGE COULD BE SUFFICIENT TO RESULT IN THE RISK OF ELECTRIC SHOCK.



WHERE MARKED, THIS SYMBOL INDICATES IMPORTANT USAGE AND MAINTENANCE INSTRUCTIONS IN THE ENCLOSED DOCUMENTS. PLEASE REFER TO THE MANUAL.

IMPORTANT SAFETY INSTRUCTIONS

- 1) Read these instructions
- 2) Keep these instructions
- 3) Heed all warnings
- 4) Follow all instructions
- 5) Do not use this apparatus near water
- 6) Clean only with dry cloth
- 7) Do not block any ventilation openings. Install in accordance with the manufacturer's instructions.
- 8) Do not install near any heat sources, such as radiators, heat registers, stoves or other apparatus (including amplifiers) that produce heat
- 9) Do not defeat the safety purpose of the polarized or grounding-type plug. A polarized plug has two blades with one wider than the other. A grounding type plug has two blades and a third grounding prong. The wide blade or the third prong are provided for your safety. If the provided plug does not fit into your outlet, consult an electrician for replacement of the obsolete outlet.
- 10) Protect the power cord from being walked on or pinched particularly at plugs, convenience receptacles, and the point where they exit from the apparatus.
- 11) Only use attachments/accessories specified by the manufacturer.
- 12) Use only with the cart, stand, tripod, bracket, or table specified by the manufacturer or sold with the apparatus. When a cart is used, use caution when moving the cart/apparatus combination to avoid injury from tip-over.
- 13) Unplug this apparatus during lightning storms or when unused for long periods of time.
- 14) Refer all servicing to qualified service personnel. Servicing is required when the apparatus has been damaged in any way, such as power-supply cord or plug is damaged, liquid has been spilled or objects have fallen into the apparatus, the apparatus has been exposed to rain or moisture, does not operate normally, or has been dropped.



THE DEVICE MUST BE CONNECTED TO THE MAINS THROUGH A POWER OUTLET WITH A PROTECTIVE EARTH CONNECTION.

This device features a power outlet ; install the device so that the outlet for the power cord is easily accessible .

PRECAUTIONS

- For proper air ventilation please make sure to leave sufficient clearance (min 11 inc.) on all sides of the device.
- Please do not cover the ventilation slots with papers, table cloths, curtains, etc. in order not to prevent ventilation of the device.
- ° Please do not place any naked flame source, such as lighted candles, on the device.
- ° Please keep the device away from water springs and splashes and please do not place any objects containing liquids, such as vases, on the device.

INTRODUCTION

FBT is proud to present the development of its renowned MaxX range, which for the last 10 years has been representing a reference point in the international market, where it proved a real best seller: **ProMaxX**.

Leaving unchanged all MaxX most successful features, we applied to this new range the technological steps forward made thanks to the work of FBT R&D laboratories: you will be astonished by its incredible quality, reliability and portability and, most of all, by the listening pleasure you will experience. Even though recalling MaxX guidelines, the elegant design of the new range is projected into the future thanks to a trendy and innovative look. Its simple use and versatility, together with the advanced technological level achieved, make it possible for **ProMaxX** range to be perfect for meeting the needs of musicians, Djs and audio hire services.

By using a high efficiency class D power amplifier module with switching power supply enclosed in a lightweight and thermally efficient die-cast aluminium chassis, it allows maximizing the loudspeaker load volume thus supplying 1200W without the need for fans.

The range includes 3 models, both active and passive versions, and an active bandpass subwoofer.

They are perfect for being used during live performances thanks to their high power and easy transport, or also as fixed installation and stage monitors.

AMPLIFIER MODULE

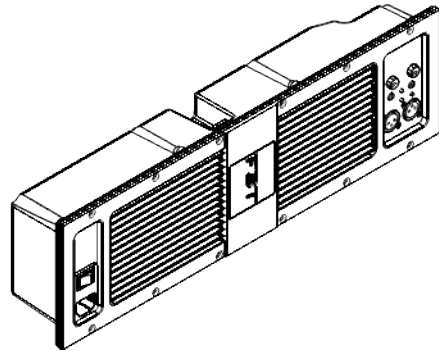
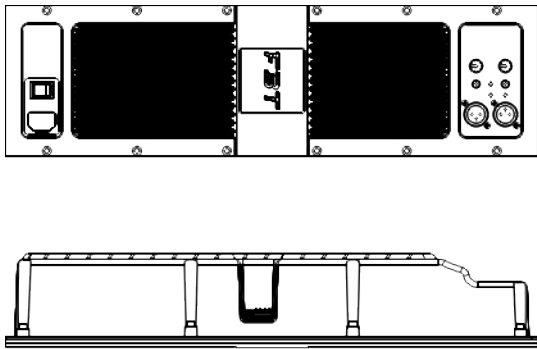

ProMaxX active systems display a high-efficiency Class D power amplifier module with switching power supply enclosed in a die-cast aluminium chassis.

This permits to protect the electronics against dust, avoid any air loss through the controls – which would cause annoying noises- and maximize heat loss by using the woofer ventilation instead of a cooling fan.

This allowed the development of a lightweight 1200W amplifier.

Pro MaxX 14a

Pro MaxX 14



2-WAY BI-AMPLIFIED BASS REFLEX DESIGN CABINET

- > New 14" LF neodymium magnet woofer with 3" voice coil, custom made for FBT by B&C
- > 1,4" exit throat B&C HF magnet compression driver with 2,5" voice coil
- > Frequency response from 45Hz to 20kHz
- > Biamped: 600W RMS LF, 300W RMS HF, class D power amplifiers with switch mode power supply
- > Digital signal processor with 8 equalization presets
- > Control panel with XLR input and link, volume, preset, HP filter, ground lift switch
- > 90°H x 60°V constant directivity horn
- > Sturdy gas-injected polypropylene molded enclosure with 2 integrated handles
- > 2 x M10 suspension points, 1,3/8" top-hat speaker stand socket, wall bracket mount flange plate
- > Dual purpose: front of house or stage floor monitor with 12°, 40°, 55° monitoring angles

PASSIVE VERSION

- > Recommended amplifier 700W RMS / 8 Ohm
- > Built in passive crossover with soft trip protection for the LF woofer and HF driver
- > Speakon NL-4 in and link connectors

Pro MaxX_{12a}

Pro MaxX₁₂



2-WAY BI-AMPLIFIED BASS REFLEX DESIGN CABINET

- > 12" LF neodymium magnet woofer with 3" voice coil, custom made for FBT by B&C
- > 1" exit throat B&C HF neodymium magnet compression driver
- > Frequency response from 48Hz to 20kHz
- > Biamped: 600W RMS LF, 300W RMS HF, class D power amplifiers with switch mode power supply
- > Digital signal processor with 8 equalization presets
- > Control panel with XLR input and link, volume, preset, HP filter, ground lift switch
- > 90°H x 60°V constant directivity horn
- > Sturdy gas-injected polypropylene molded enclosure with 2 integrated handles
- > 2 x M10 suspension points, 1,3/8" top-hat speaker stand socket, wall bracket mount flange plate
- > Dual purpose: front of house or stage floor monitor with 12°, 40°, 55° monitoring angles
- > Extremely light, only 33,1 lb

PASSIVE VERSION

- > Recommended amplifier 600W RMS / 8 Ohm
- > Built in passive crossover with soft trip protection for the LF woofer and HF driver
- > Speakon NL-4 in and link connectors

ProMaxX_{10a}

ProMaxX₁₀



2-WAY BI-AMPLIFIED BASS REFLEX DESIGN CABINET

- > 10" LF neodymium magnet woofer with 2,5" voice coil, custom made for FBT by B&C
- > 1" exit throat B&C HF neodymium magnet compression driver
- > Frequency response from 55Hz to 20kHz
- > Biamped: 600W RMS LF, 300W RMS HF, class D power amplifiers with switch mode power supply
- > Digital signal processor with 8 equalization presets
- > Control panel with XLR input and link, volume, preset, HP filter, ground lift switch
- > 90°H x 60°V constant directivity horn
- > Sturdy gas-injected polypropylene molded enclosure with integrated handle
- > 2 x M10 suspension points, 1,3/8" top-hat speaker stand socket, wall bracket mount flange plate
- > Dual purpose: front of house or stage floor monitor with 12°, 40°, 55° monitoring angles
- > Extremely light, only 24,7 lb

PASSIVE VERSION

- > Recommended amplifier 400W RMS / 8 Ohm
- > Built in passive crossover with soft trip protection for the LF woofer and HF driver
- > Speakon NL-4 in and link connectors

ProMaxX 15S_a



BAND PASS DESIGN SUBWOOFER WITH HIGH SPL AND PUNCH

- > 15" high excursion woofer with 3" voice coil, custom made for FBT by B&C
- > Frequency response from 38Hz to 120Hz
- > 1200W RMS class D power amplifiers with switch mode power supply
- > Digital signal processor with 8 presets, 2 equalization with 4 LPF different frequency

- > Control panel with XLR input and link, volume, EQ preset, Delay, Phase switch 0°-180°, ground lift switch
- > 5/8" baltic birch plywood cabinet with scratch & scuff resistant paint finish
- > M20 top mount speaker stand socket, two aluminium carrying handles
- > Provides additional low frequency reinforcement when used along with 2-way ProMaxX series

Pro MaxX 10a

Pro MaxX 12a

Pro MaxX 14a

PRESET: select 8 preset, each of whom corresponds to a different equalization according to user's personal preferences and to the acoustics of the listening area (see PRESET section)

LEVEL: adjusts the signal general level

GND LIFT: a switch for the electric separation between the ground and earth circuits; this can be useful in order to remove the irritating noises caused by ground loops

ON: indicates that the system is on

HP FILTER: this switch activates the low-cut filter which lets only the frequencies above the cut-off frequency pass at the output

PEAK: when this led lights up it indicates that the signal is reaching saturation

LMT/PRT: if this led lights up there is a system malfunction due to an internal amplifier failure or to the intervention of current limiting circuits against thermal overload

IN-LINK: balanced input/output sockets; "IN" allows to connect a pre-amplified signal such as that coming, for instance, from mixer output; "LINK" allows to connect multiple speakers to the same signal.

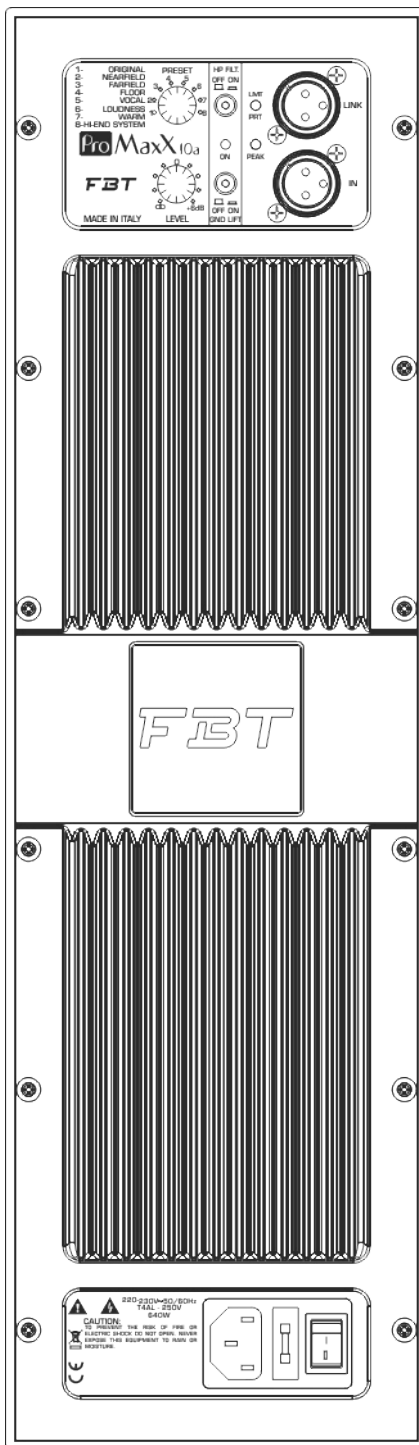

POWER SUPPLY

Before connecting the apparatus to the mains, make sure the supply voltage matches the one indicated on the back of the apparatus. The power socket also included a fuse box; faulty fuses shall be replaced only with fuses having the same electrical features and value.

220 - 230V

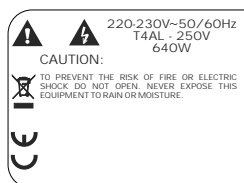

120V



ProMaxX 155a

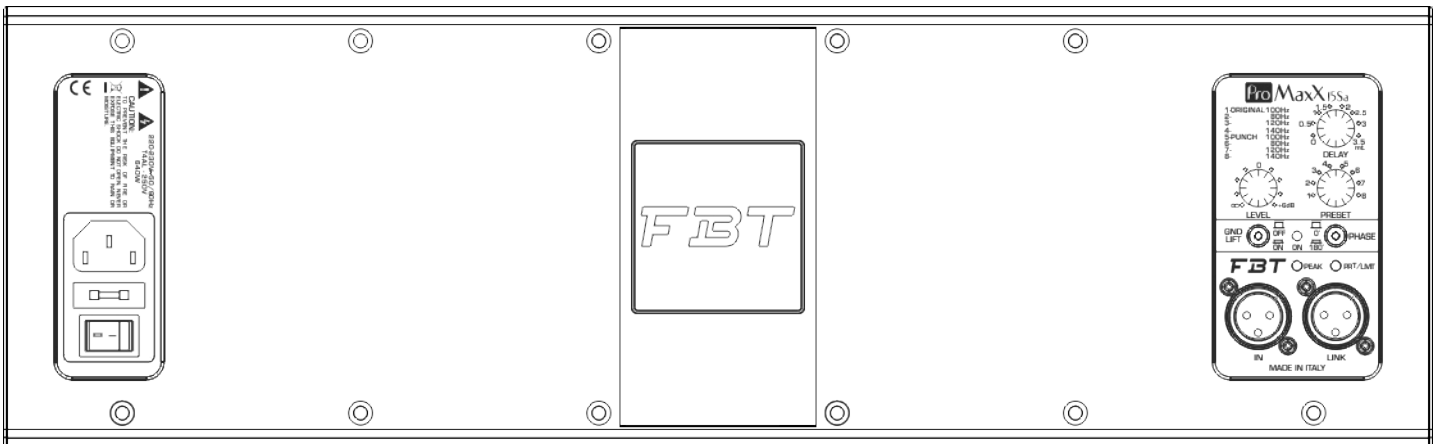

LEVEL: adjusts the signal general level

DELAY: control of a digital delay line acting on the input signal; in this way it is possible to make up for the vertical misalignment of sub and satellite. The delay is expressed in metres and goes from 0.5 to 3.5 mt. with 50cm steps

PRESET: select 8 preset, each of whom corresponds to a specific speaker configuration according to user's personal preferences and to the acoustics of the listening area (see PRESET section)

GND LIFT: a switch for the electric separation between the ground and earth circuits; this can be useful in order to remove the irritating noises caused by ground loops

ON: indicates that the system is on

PHASE: the Phase control allows to optimize phase alignment, i.e. to obtain a uniform frequency response in the crossover area between the sub and the satellite. When it is set at 0° the sound emission is in phase with the input signal; when it is set at 180° the sound emission is in counterphase with the input signal; thanks to this control subwoofer adjustment will be even more flexible with a consequent performance optimization

PEAK: when this led lights up it indicates that the signal is reaching saturation

LMT/PRT: if this led lights up there is a system malfunction due to an internal amplifier failure or to the intervention of current limiting circuits against thermal overload

IN-LINK: balanced input/output sockets connected in parallel mode; "IN" allows to connect a pre-amplified signal such as that coming, for instance, from mixer output; "LINK" allows to connect multiple speakers to the same signal.

ALIMENTAZIONE

Before connecting the apparatus to the mains, make sure the supply voltage matches the one indicated on the back of the apparatus. The power socket also included a fuse box; faulty fuses shall be replaced only with fuses having the same electrical features and value.

220 - 230V

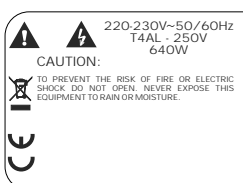

120V

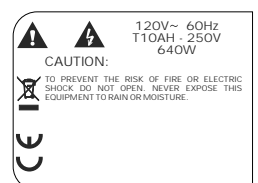

Pro MaxX₁₀
Sound Reinforcement Speaker

FBT

CAUTION:
IT IS IMPORTANT TO USE AN AMPLIFIER THAT DOES NOT EXCEED 400W RMS @ 8 OHMS.

Nominal Impedance :	8 Ohm
Recommended Amplifier	400 W RMS
Short Term Power :	800 W
Long Term Power :	200 W
Frequency Response (@-6dB):	60 Hz - 18 kHz
Sensitivity @ 1W,1m :	97 dB
Max SPL cont. / peak :	123 / 127 dB
Dispersion :	90° H x 60° V

FBT elettronica spa - RECANATI (MC) **MADE IN ITALY**

Pro MaxX₁₂
Sound Reinforcement Speaker

FBT

CAUTION:
IT IS IMPORTANT TO USE AN AMPLIFIER THAT DOES NOT EXCEED 600W RMS @ 8 OHMS.

Nominal Impedance :	8 Ohm
Recommended Amplifier	600 W RMS
Short Term Power :	1200 W
Long Term Power :	300 W
Frequency Response (@-6dB):	55 Hz - 18 kHz
Sensitivity @ 1W,1m :	99 dB
Max SPL cont. / peak :	126 / 130 dB
Dispersion :	90° H x 60° V

FBT elettronica spa - RECANATI (MC) **MADE IN ITALY**

Pro MaxX₁₄
Sound Reinforcement Speaker

FBT

CAUTION:
IT IS IMPORTANT TO USE AN AMPLIFIER THAT DOES NOT EXCEED 700W RMS @ 8 OHMS.

Nominal Impedance :	8 Ohm
Recommended Amplifier	700 W RMS
Short Term Power :	1400 W
Long Term Power :	350 W
Frequency Response (@-6dB):	50 Hz - 18 kHz
Sensitivity @ 1W,1m :	100 dB
Max SPL cont. / peak :	128 / 132 dB
Dispersion :	90° H x 60° V

FBT elettronica spa - RECANATI (MC) **MADE IN ITALY**

Speakon connectors are connected in parallel mode. One connector can be used to connect the box to the output of a power amplifier, the other to connect to a second box.

Loudspeaker cables shall have the adequate diameter, depending on the overall length of the connection. The resistance introduced by an inadequate wiring towards the loudspeakers would reduce both the power output and the damping factor of the loudspeaker.

*SPEAKON is a registered trademark of NEUTRIK

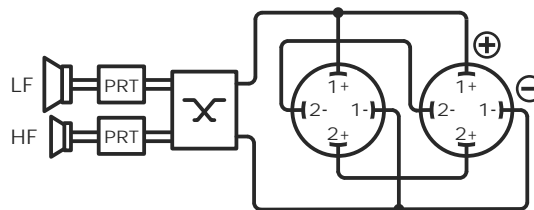

PRESET

Instead of rotary EQ controls, FBT's new Digital Signal Processor with 8 factory equalization presets provides simple and efficient EQ adjustment. Hundreds of hours of testing in the anechoic chamber in our factory went into the development of these presets to optimize the ProMaxX speakers for use for numerous applications. Selection is made through the "PRESET" switch.

PRESET 10A / 12A / 14A

- **ORIGINAL:** corresponds to the typical FBT sound; it is the default general purpose preset and is thus fit for the majority of applications

- **NEARFIELD:** suitable for a very close listening, up to 7-8 meters. Recommended for small rooms or with a very close audience where a medium-high SPL is anyway required

- **FARFIELD:** for listening to the speaker at a distance over 15-20 meters; Suitable when the sound has to be projected over long distances

- **FLOOR:** The speaker has specialized and works as stage monitor. The answer is balanced to take into account the proximity to the floor and the listening of sounds in a nearfield.

- **VOCAL:** Allows obtaining top intelligibility of spoken language even in difficult environments or with high noise floor. The passband is modified to emphasize vocal range.

- **LOUDNESS:** Typical answer curve for music application or record, with bass and treble emphasized with respect to the middle frequencies that, instead, remain slightly in the background. This preset is very satisfying if listened to at low volume but is also suitable for using the speaker in discos and pubs.

- **WARM:** Gives a dense sound quality on middle-low frequencies and a less aggressive quality on trebles. Suitable for broadcasting music in very sound-absorbing environments or in situations that require a very strong sound at low frequencies and a sweet sound at middle-high frequencies.

- **HI-END SYSTEM:** It is characterized by the typical answer of top class speakers that are exclusively designed for touring applications; therefore, very linear answer and passband without too much extension on the extremes. Those who are used to working with highly professional audio systems will find what they look for in this preset.

PRESET 15SA

- **ORIGINAL:** corresponds to the typical FBT sound; it is the default general purpose preset and is thus fit for the majority of applications.

- **PUNCH:** the sound of the sub becomes drier, reduced low frequency extension but more energy concentrated in the 80-120Hz range. Suitable for rock music and high SPL applications.

Two presets feature 4 different cut-off frequencies (80, 100, 120, 140Hz) enabling sub configuration with any other speaker.

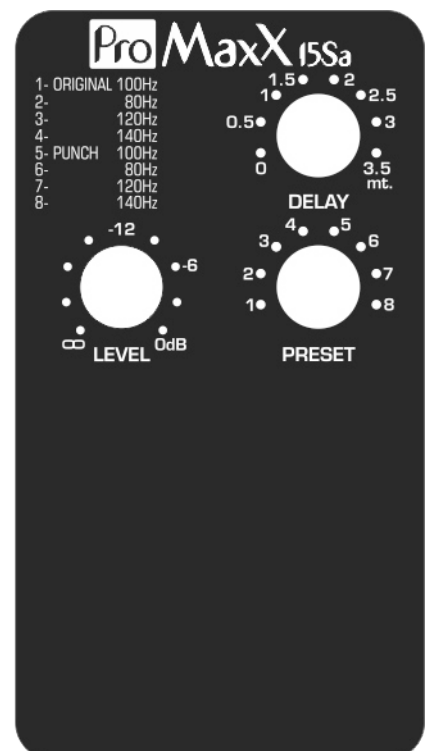
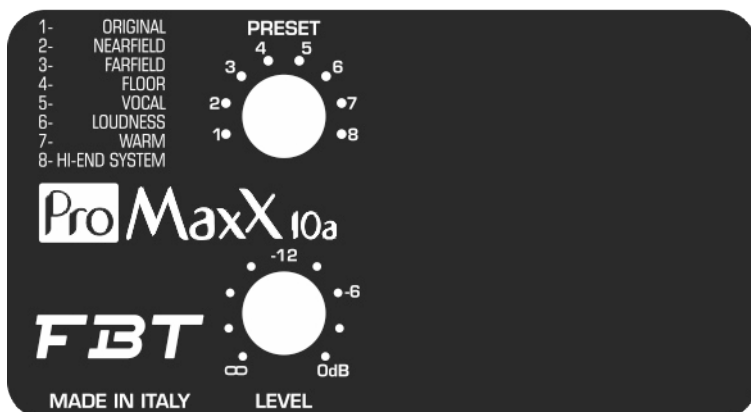

CONNECTORS

The 3-pole XLR connectors are almost always used for conducting mono-balanced signals; the three poles correspond respectively to ground (1), the positive signal (2) and the negative signal (3).

SPEAKON is a connector which is specially adapted for connecting power terminals to loudspeakers; when inserted in an appropriate socket it locks so as to prevent accidental disconnection; moreover, it is equipped with protection against electrical shocks and guarantees the correct polarisation.

The JACKS are typical connectors for the transporting of two separate signals through two channels, left and right, using a single connector and therefore they can be either mono or stereo. Mono jacks (TS) also known as unbalanced jacks, are recognisable from stereo or balanced jacks (TRS) by their composition. The point of the mono jacks is divided into two parts, tip and ground (Sleeve) to which the two poles are connected; the stereo or balanced jacks are divided in three parts, as they have a central ring (Ring) which is connected to a second wire, the third (negative) pole.

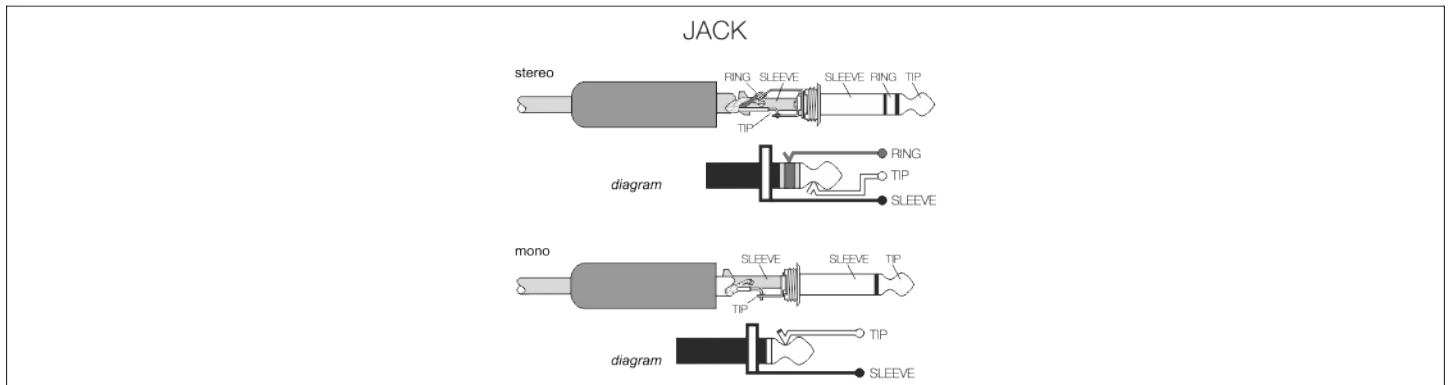
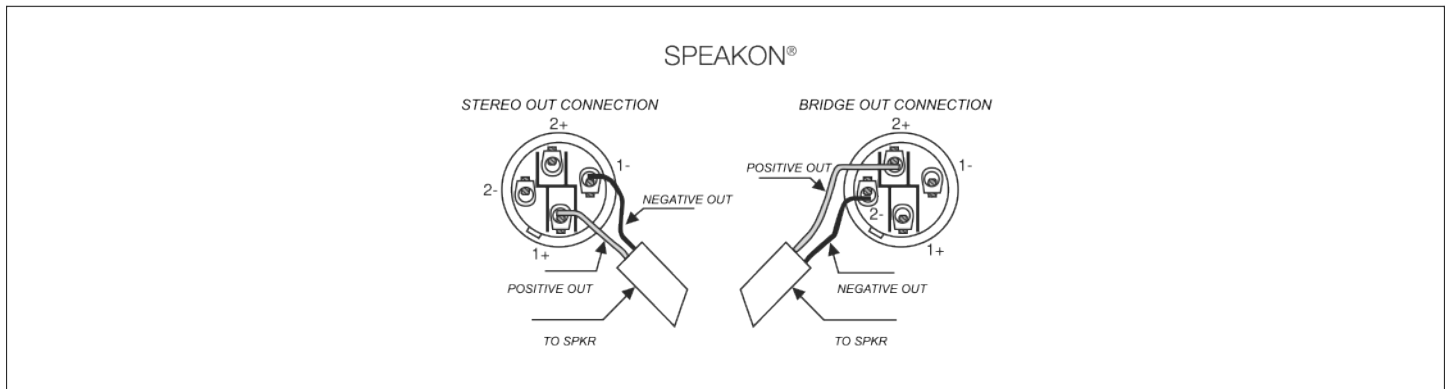
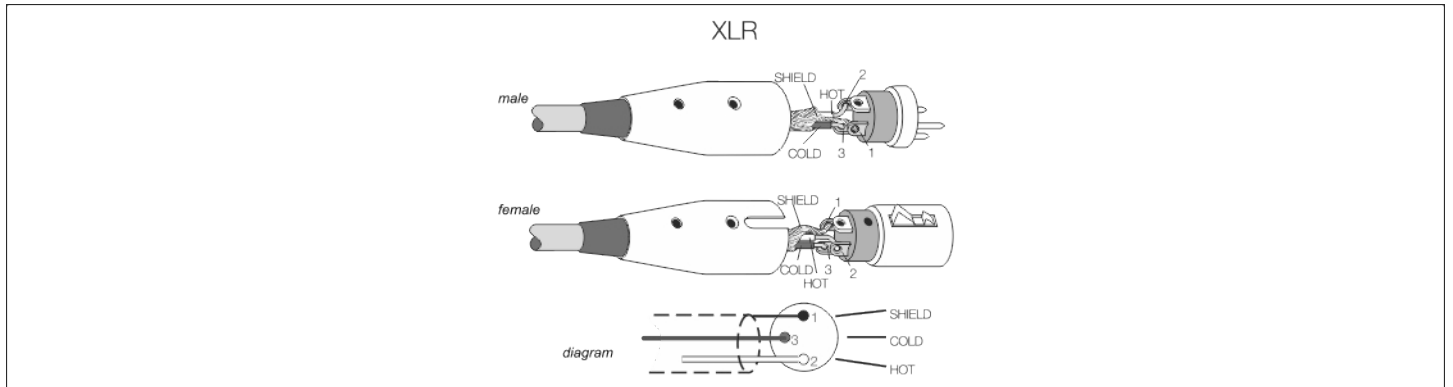

DIMENSIONS

ProMaxX₁₀

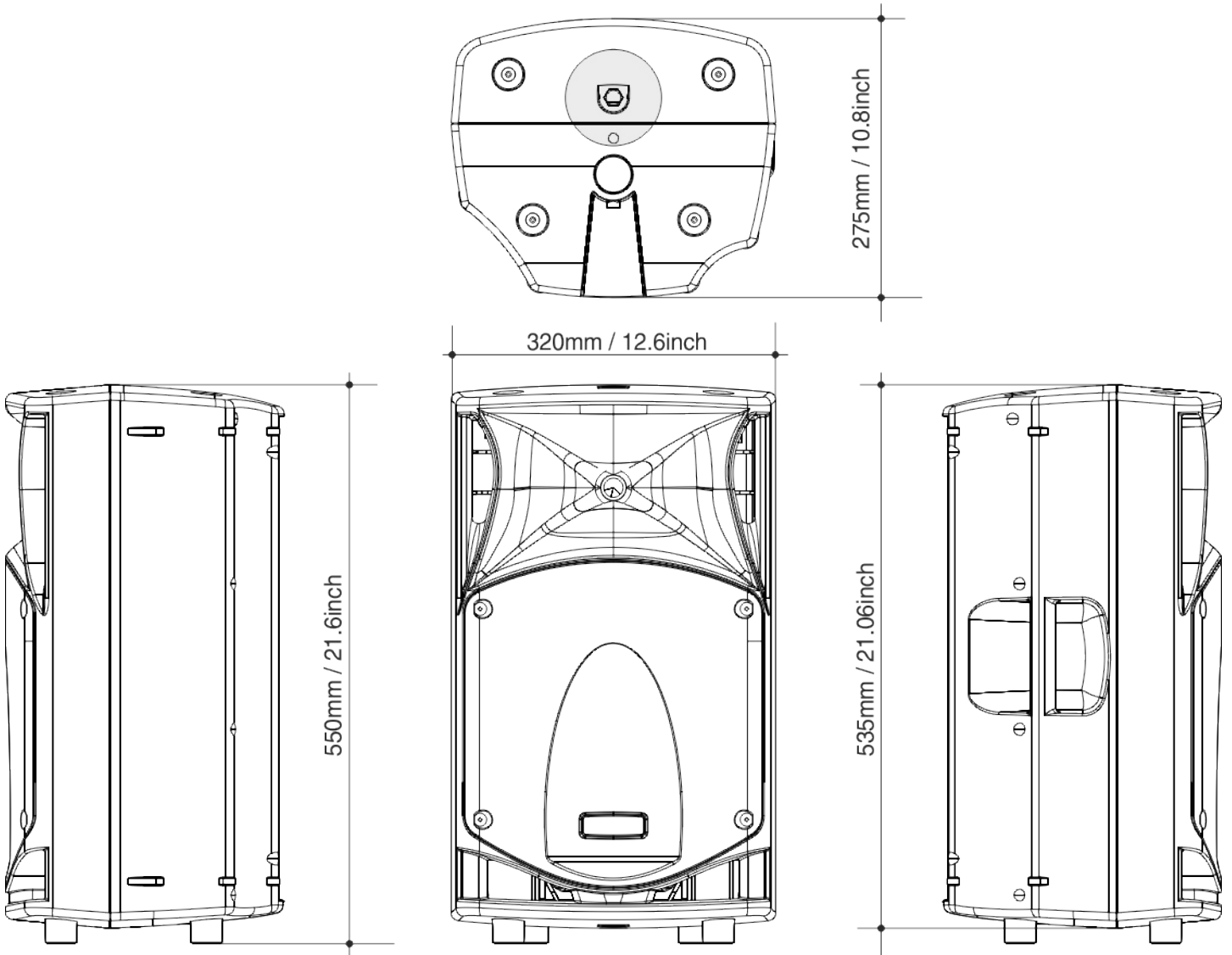

M10 SUSPENSION POINTS FOR **ONLY ONE** SPEAKER SUSPENDED

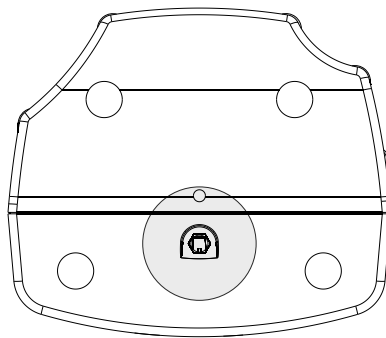
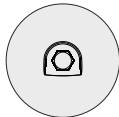

Two way cabinets have 3 monitor tapers for use as a floor wedge at 12°, 45°, 55°, providing extraordinary versatility for monitor placement on stage.

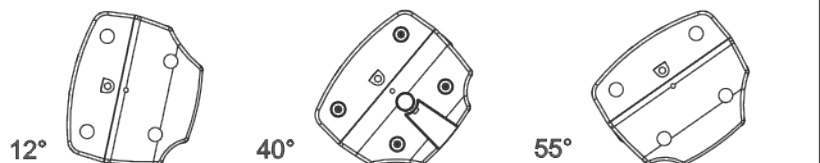

DIMENSIONS

Pro MaxX₁₂

Pro MaxX₁₄

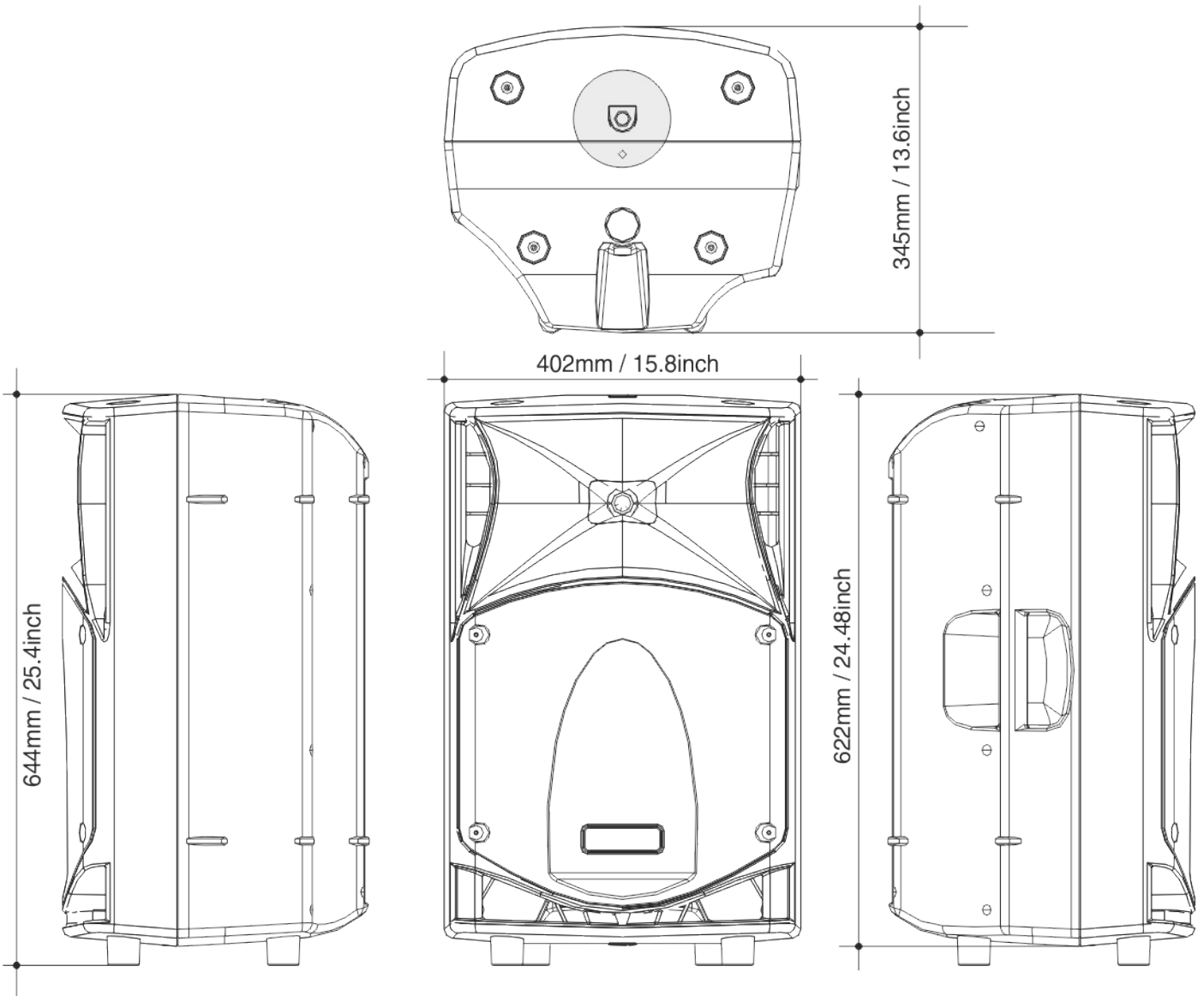

M10 SUSPENSION POINTS FOR ONLY ONE SPEAKER SUSPENDED

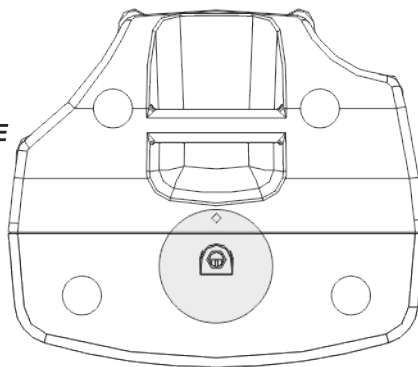

Two way cabinets have 3 monitor tapers for use as a floor wedge at 12°, 45°, 55°, providing extraordinary versatility for monitor placement on stage.

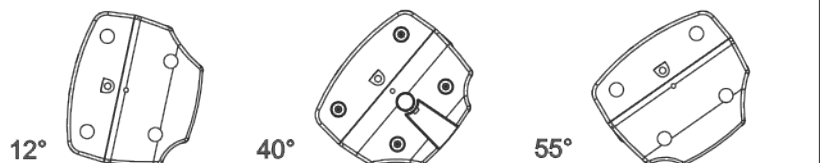

DIMENSIONS

ProMaxX 15Sa

ONLY FOR GROUND STACK CONFIGURATION

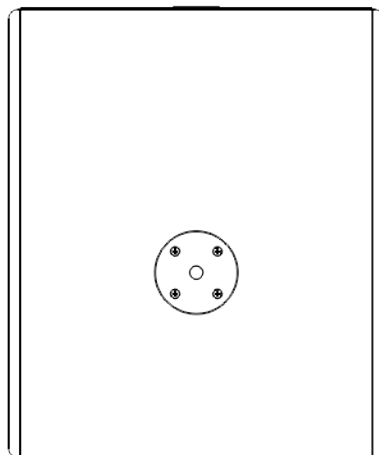
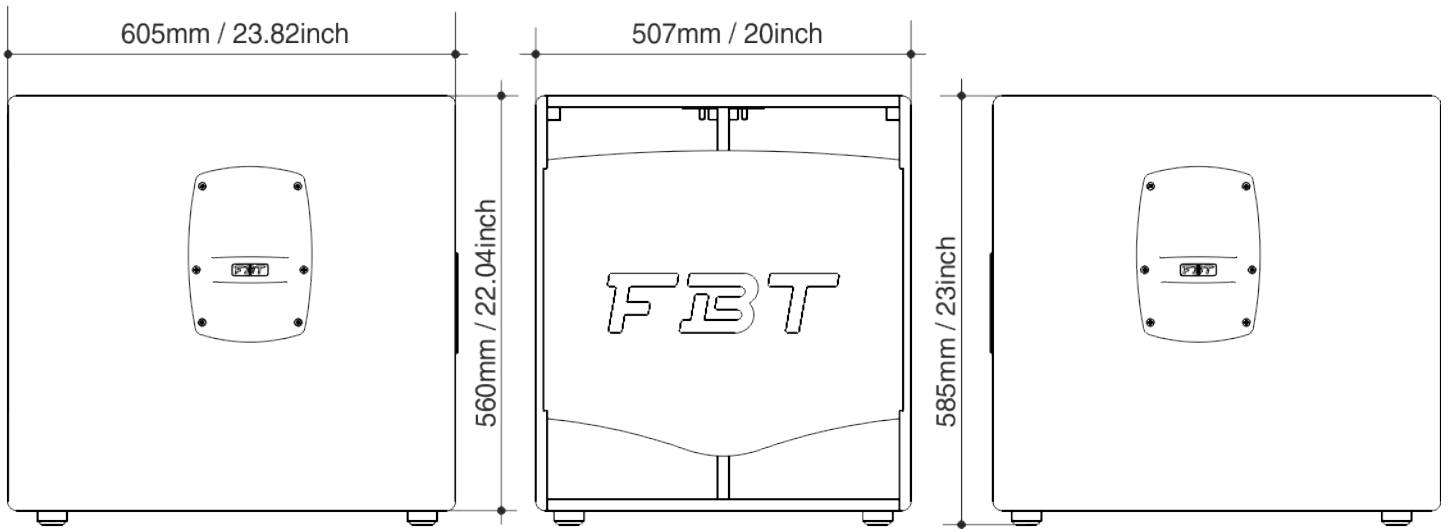
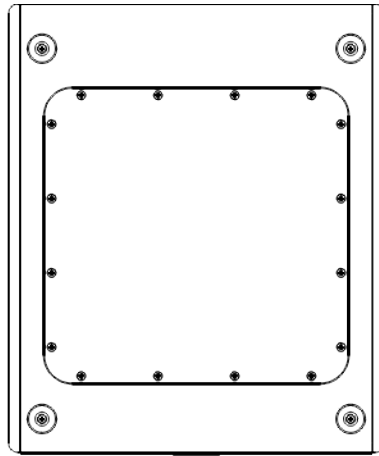

SAFETY INSTRUCTIONS

ProMaxX sound speakers must be installed using the flying accessories described in this manual and following the special assembly instructions by qualified staff only, strictly complying with the current regulations and safety standards in force in the country of installation.

FBT flying accessories are manufactured for their exclusive use with **ProMaxX** systems and have not been designed for being used with any other speaker or device.

Any possible elements of the ceiling, floor or further supports where **ProMaxX** systems are to be installed shall be able to safely bear the load. The flying accessories in use are to be coupled and secured safely to both the sound speaker and the ceiling (or the other support).

When components are fitted to ceilings, floors or beams, always make sure that all couplers and fixing elements are properly sized and have an adequate load capacity.

Besides the main suspension system, all flying speakers in theatres, indoor stadiums or in several other work and/or leisure facilities shall be provided with an additional independent safety system with the adequate load capacity. Only steel cables and chains with certified load capacity can be used as an additional safety device.

WARNING

- Hang **ProMaxX** speakers using only original accessories
- When choosing the place of installation, the suspension cable and the mounting supports make sure they are able to bear speaker and flying accessories' weight with the proper safety factor
- As for fixed installations, always schedule and carry out special inspections on a regular basis in order to check all the parts that have to guarantee system safety over time
- Do not hang the system by the handles: handles have been designed for speaker transport and are not suitable for its suspension
- Never lean on/hang from the flying speaker

FBT Elettronica SpA accepts no responsibilities for any possible damages or injuries due to the use of supports or structures not strong enough or due to wrong installation

ACCESSORIES

CAUTION

The ProMaxX speakers use only with FBT mount for wall installation.

USE WITH OTHER MOUNTS IS CAPABLE OF RESULTING IN INSTABILITY CAUSING POSSIBLE INJURY.

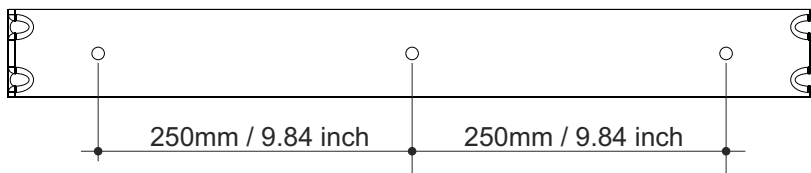
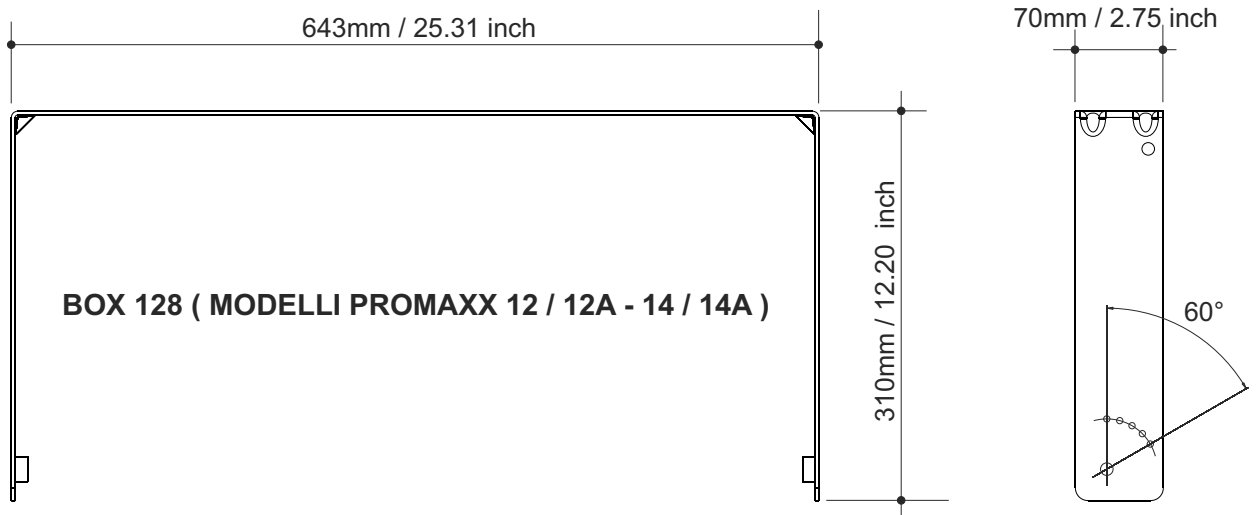
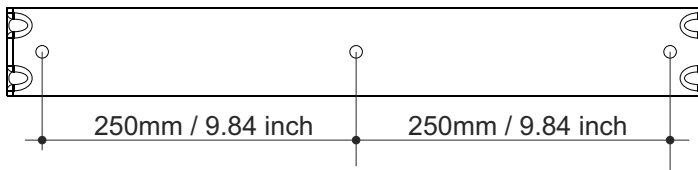
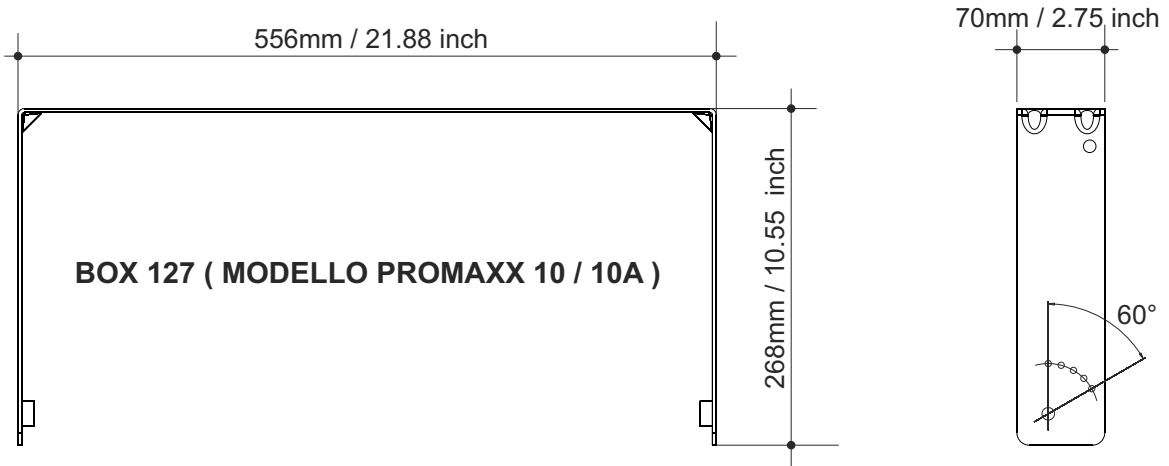

INSTALLATION MODES

ProMaxX speakers can be installed as follow:

- a) suspension by wall bracket (except for ProMaxX 15SA)
- b) installation on tripod stand or coupled with the subwoofer
- c) simple stack installation with the subwoofer on the ground and the relevant satellite on it

Suspension by wall bracket



- 1) Carefully choose speakers place of installation and make sure that the structure can bear box weight
- 2) Remove speaker's four feet
- 3) Secure the bracket to the wall by using screws in all its fixing holes
- 4) Place the speaker between bracket arms and secure it through two M10 threaded inserts
- 5) Point the speaker as desired and lock it through the M6 pin

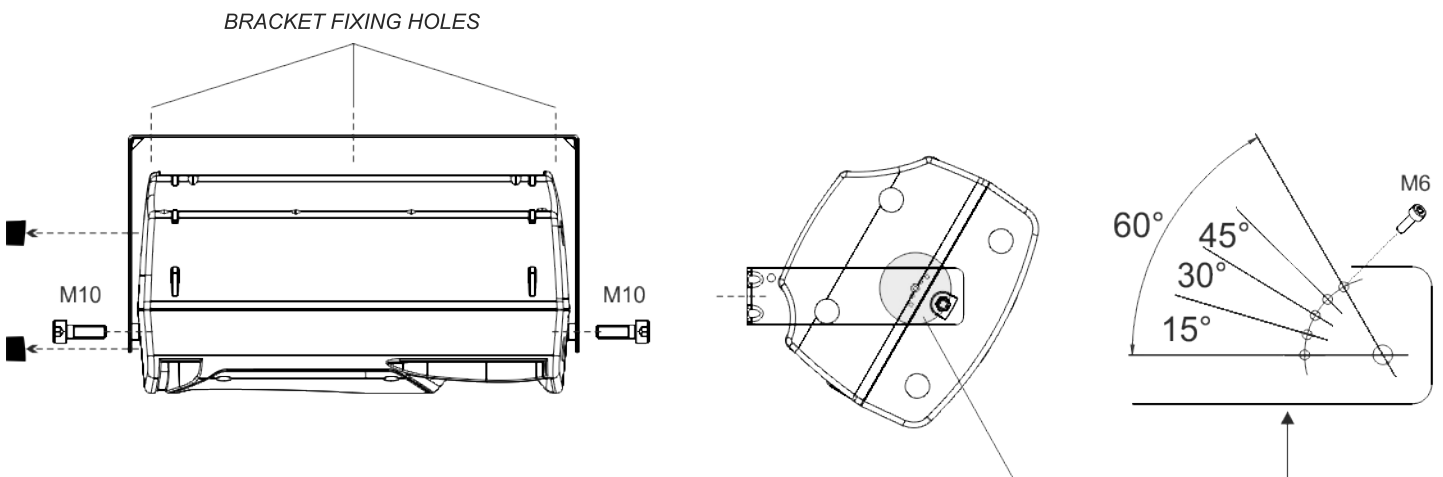

INSTALLATION MODES

Installation on tripod stand

All ProMaxX satellites are designed to be installed on floor stand. Such installation will allow medium-high frequency sources to be better aligned to listener's ear.

With this installation take the following precautions:

- _ Make sure that the stand can bear speaker's weight
- _ Place the stand on a flat and antislip surface
- _ Widen stand base as much as possible to increase its stability

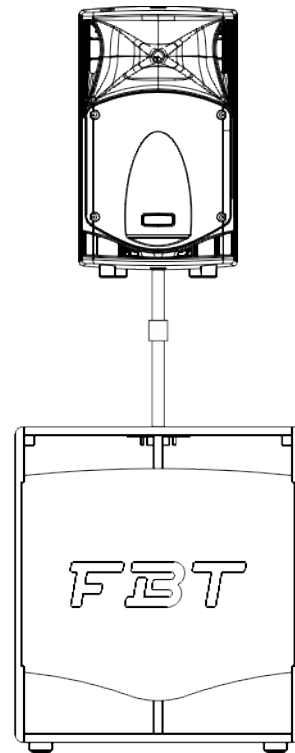
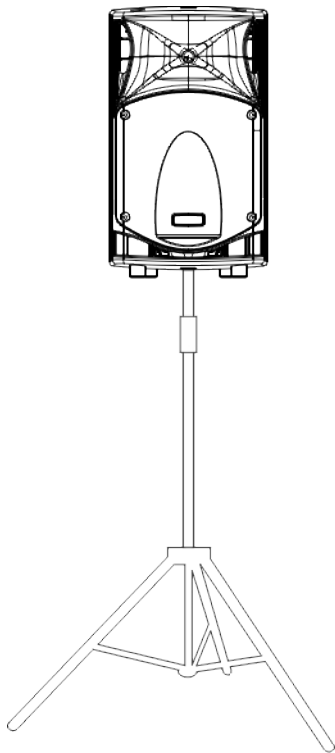

Stack installation

Subwoofer on the ground and the relevant satellite on it

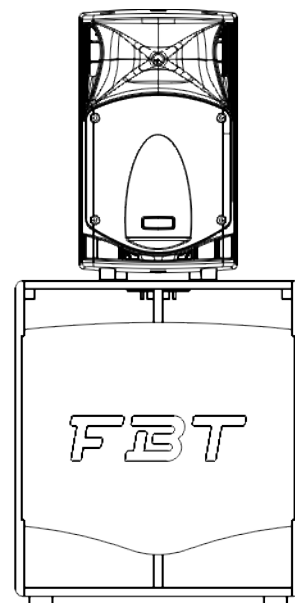
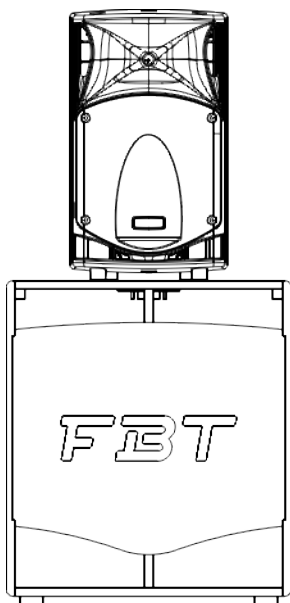

CONNECTION EXAMPLES

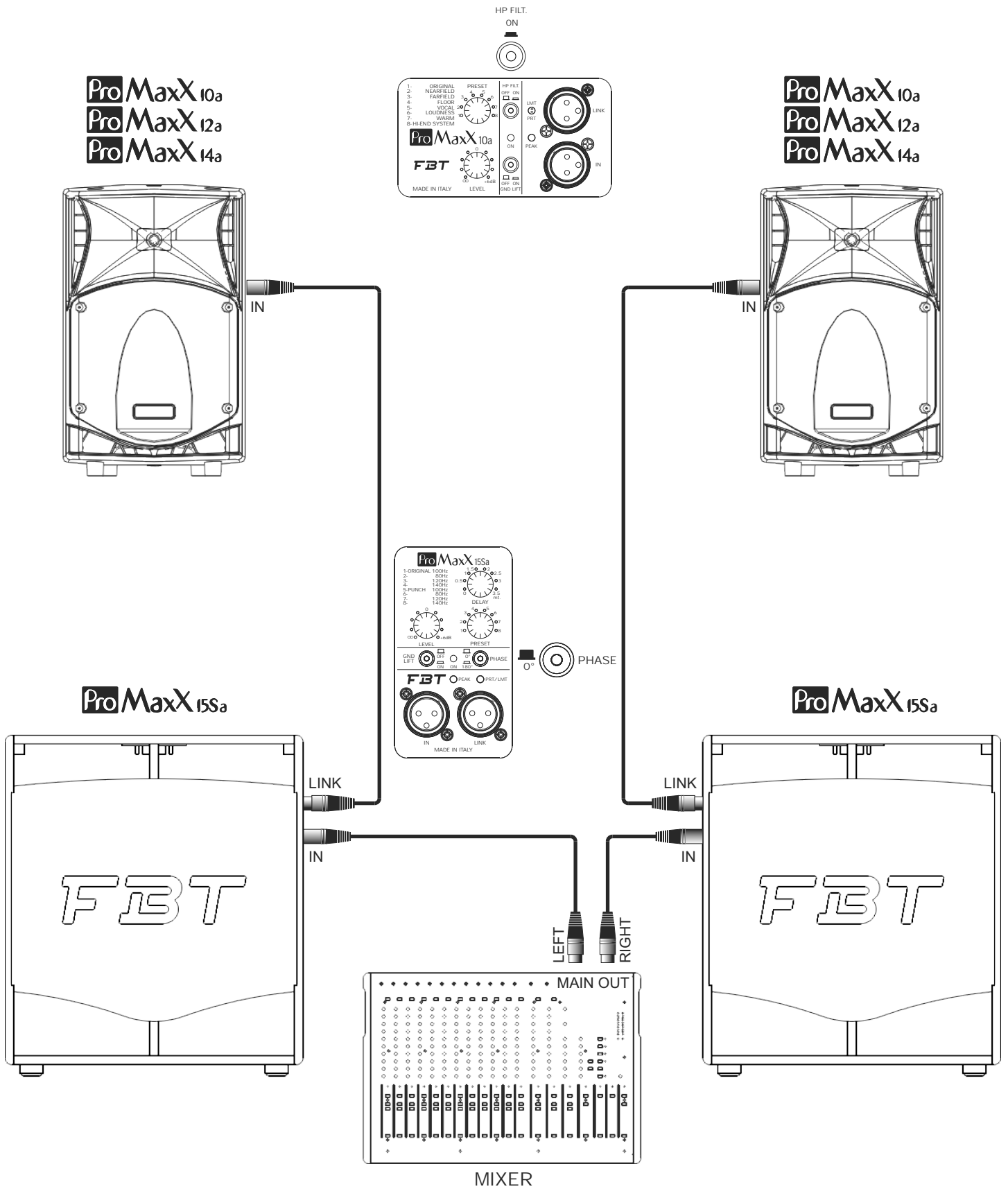

For sub/satellite configurations set sub PHASE switch to "0°" and satellite HP FILTER switch to "ON".

TECHNICAL SPECIFICATIONS

		ProMaxX 14A	ProMaxX 12A	ProMaxX 10A	ProMaxX 15SA
Configuration	way	2	2	2	1
Built-in Amplifier cont. RMS LF/HF	W	400/200	400/200	400/200	800
Built-in Amplifier max. RMS LF/HF	W	600/300	600/300	600/300	1200
Built-in Amplifier max. peak. LF/HF	W	1200/600	1200/600	1200/600	2400
Frequency Response	-6dB	45Hz-20kHz	48Hz-20kHz	58Hz-20kHz	38Hz-120Hz
Low Frequency Woofer	inch	1x14 / coil 3	1x12 / coil 3	1x10 / coil 2.5	1x15 / coil 3
High Frequency Driver	inch	1x1.4 / coil 2.5	1x1 / coil 1.4	1x1 / coil 1.4	-----
Max. SPL cont/peak	dB	127.5 / 135.5	126 / 133	124 / 131	132 / 136 half-space
Dispersion	HxV	90°x60°	90°x60°	90°x60°	omnidirectional
Input Impedance	kOhm	22	22	22	22
Crossover Frequency	kHz	1.3	1.6	1.8	preset dependant
AC Power Requirement	VA	640	640	640	640
Input Connectors		XLR with loop	XLR with loop	XLR with loop	XLR with loop
Power Cord	ft	16.4	16.4	16.4	16.4
Net Dimensions (WxHxD)	inch	15.8x25.4x13.6	15.8x25.4x13.6	12.6x21.6x10.8	20x23x23.82
Net Weight	lb	38.3	34.8	24.9	65
Transport Dimensions (WxHxD)	inch	19.7x29.3x17.3	19.7x29.3x17.3	15.7x24.8x14.2	24.2x26.4x28.2
Transport Weight	lb	45	41.4	29.4	73.8
		ProMaxX 14	ProMaxX 12	ProMaxX 10	
Configuration	way	2	2	2	
Recommended Amplifier (rms)	W	700	600	400	
Long Term Power	W	350	300	200	
Short Term Power (IEC 268-5)	W	1400	1200	800	
Nominal Impedance	Ohm	8	8	8	
Frequency Response	-6dB	50Hz-18kHz	55Hz-18kHz	60Hz-18kHz	
Low Frequency Woofer	inch	1x14 / coil 3	1x12 / coil 3	1x10 / coil 2.5	
High Frequency Driver	inch	1x1.4 / coil 2.5	1x1 / coil 1.4	1x1 / coil 1.4	
Sensitivity (@1W/1mt)	dB	100	99	97	
Max SPL cont/peak	dB	128 / 132	126 / 130	123 / 127	
Dispersion	HxV	90°x60°	90°x60°	90°x60°	
Crossover Frequency	kHz	1.3	1.6	1.8	
Recommended HP Filter		40Hz-24dB oct	45Hz-24dB oct	50Hz-24dB oct	
Input Connectors		2 x speakon	2 x speakon	2 x speakon	
Net Dimensions (WxHxD)	inch	15.8x25.4x13.6	15.8x25.4x13.6	12.6x21.6x10.8	
Net Weight	lb	35.2	31.3	22	
Transport Dimensions (WxHxD)	inch	19.7x29.3x17.3	19.7x29.3x17.3	15.7x24.8x14.2	
Transport Weight	lb	41.8	38.1	27.5	

TECHNICAL SPECIFICATIONS

AES LONG TERM APPLICABLE POWER denotes the thermal power that can be dissipated by the loudspeaker or by the individual drivers when operated in BI-AMP mode. This value is measured in accordance with the AES standard, which involves a 2 hour test with pink noise signal, crest factor of 2. Power is determined by the square of the RMS voltage divided by the minimum impedance of the loudspeaker or the individual driver.

IEC268-5 SHORT TERM APPLICABLE POWER corresponds to the power that the loudspeaker can withstand for a very short time interval. This value corresponds to 4 times the AES power value and it is calculated on the basis of the maximum peak voltage that the recommended amplifier can supply to the loudspeaker. Capacities in terms of SPL in transient components of music signals, effectively correspond to the short term applicable power value; therefore, the max. SPL value specified in the technical specifications table is calculated on the basis of this power value

WARNING: the power value that effectively corresponds to the thermal capacity of the loudspeaker to dissipate electrical energy over the long term is represented by the AES value. All other values refer to the "transient capacity" of the loudspeaker to accept power inputs, correlated with the nature of the audio signal.

Although the power of **THE RECOMMENDED AMPLIFIER** is not measured, it is equivalent to double the AES power value and it takes account of the dynamic capacities of the speakers to withstand short duration power peaks. The value supplied corresponds to the RMS power required of the amplifier in order to supply the test signal (pink noise with crest factor 2) utilised to measure AES power.

An amplifier of this power, if used with music signals with crest factor greater than or equal to 6dB, makes it possible to get the best performance out of the speaker, delivering a long term power output that is no higher than the AES power of the loudspeaker.

On the contrary, when using highly compressed music signals or if the amplifier volume is increased to the point of intensive clipping, then the effective long term power tends to reach or even exceed the RMS output of the amplifier, resulting in irreversible damage to the speakers.

With signals of this type it is always advisable to use an amplifier whose RMS output is identical to the speaker AES power, while taking care to ensure that the signal supplied is such that the amplifier is not caused to function in clipping mode too frequently.

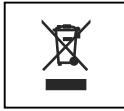

WARNING: where affixed on the equipment or package, the barred waste bin sign indicates that the product must be separated from other waste at the end of its working life for disposal. At the end of use, the user must deliver the product to a suitable recycling centre or return it to the dealer when purchasing a new product. Adequate disposal of the decommissioned equipment for recycling, treatment and environmentally compatible disposal contributes in preventing potentially negative effects on the environment and health and promotes the reuse and/or recycling of equipment materials. Abusive product disposal by the user is punishable by law with administrative sanctions.

CODE 33272 # 300810 # REV.01

All informations included in this operating manual have been scrupulously controlled; however FBT is not responsible for eventual mistakes. FBT Elettronica SpA has the right to amend products and specifications without notice.